

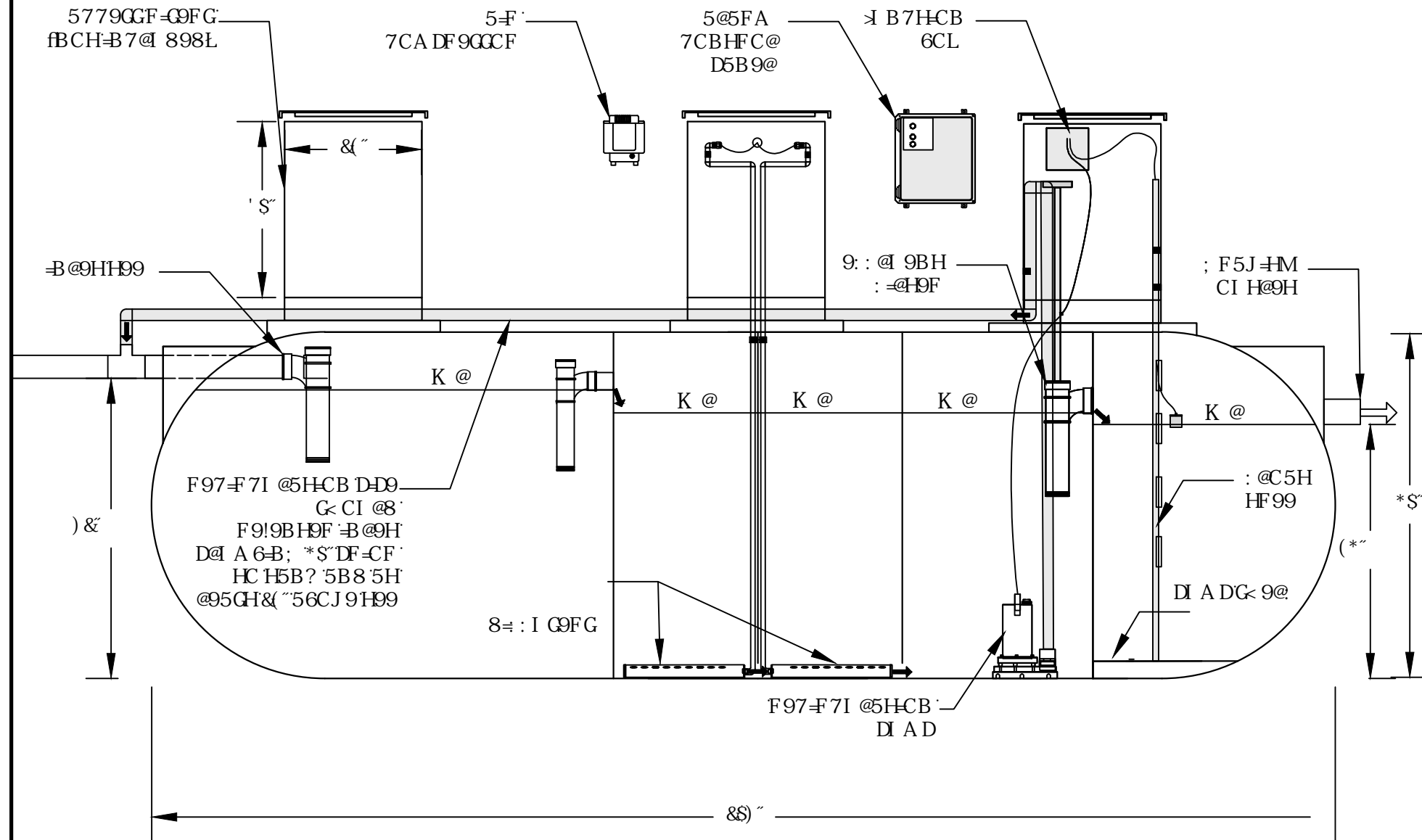

ENVIROSERVER CS450-800



CS450-800		
	Influent	Effluent
GPD (Gallons Per Day)	450	
BOD (mg/L)	601-800	30
TSS (mg/L)	501-700	30
TN (mg/L)	75	50% Reduction
FOG (mg/L)	25* May Require Grease Trap	<5
Total Organic Load (#)	3#	
Alkalinity	7 mg/L TN: 1 mg/L CaCO3 Ratio Min 150	
PH	7.0-7.5	
Ammonia NH3	75	

Product Supplied by MicroSepTec	
Tank	2000 Gallon 5 Compartment Tank
Recirculation Pump	Mechanical Recirculation
Alarm Control Panel	Standard Gravity (options available)
Power Requirement	120V 15AMP Single Circuit
Aeration	Two(2) Linear Compressors
Bio-Media	2'
Diffusers	High Capacity Diffusers
Lids	Non Traffic Rated

Options	
Control Panel	Simplex/Duplex discharge
Power Requirements	One (1) 15A and one (1) 20 A breaker
Disinfection	UV or Chlorination
Telemetry	Proprietary
Products/Options supplied by others	
Discharge pumps	Sized according to design
Flow Meter	Required for 50% or Greater Reduction in TN
Riser Adapters and Risers	Locally Obtained

MODEL: CS450-800 ENVIROSERVER ADVANCED WASTEWATER TREATMENT SYSTEM		PROJECT: PRODUCT DRAWING		 1(877)4SEPTIC [1-877-473-7842] www.microseptec.com	
SCALE: NONE	DRAWN BY: MJS	ORG. DWG DATE: 12/30/2019	REV. DWG DATE: 01/10/2024		